

BarChip⁶⁰

Description

BarChip60, a Structural Synthetic Fibre from Elasto Plastic Concrete's range of copolymer fibres, evolved from EPC's "Future Fibre" research and development program. The aim of this program is to develop a range of fibres that achieve the highest performance levels ever seen in structural synthetic fibre reinforcement systems. The latest advances in copolymer technology, engineering design and manufacturing techniques have been incorporated into BarChip60 to deliver a fibre that is unequalled in usability, durability and service performance. BarChip60 is suitable for use in ground support in high deformation applications.

Close up of BarChip Fibre

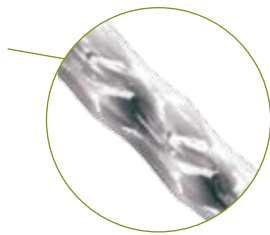

Product Features

Characteristic	Material Property
Base Resin	Modified Olefin
Length	60mm
Tensile Strength	640 MPa
Surface Texture	Continuously embossed
No. fibres per kg	33,000
Specific Gravity	0.90 - 0.92
Youngs Modulus	10 GPa
Melting Point	159°C - 179°C
Ignition Point	Greater than 450°C

Benefits

- Lower cost per Joule fibre
- Weather proof pallet packaging
- Flexural toughness equal to steel
- Long term durability ~ corrosion free
- Safer and lighter to handle than steel
- Reduced fire damage ~ anti-spalling
- Reduced wear on concrete pumps and hoses

Dosage

EPC's BarChip60 has an effective dosage range of 3kg to 10kg per cubic metre. Dosage rates should be selected based on performance requirements. Typical dosage rates for Shotcrete applications in normal ground conditions range from 4kg to 6kg per cubic metre. For assistance in specifying a dosage rate for your project please contact an EPC representative.

Mixing

To achieve optimum fibre distribution during mixing it is recommended the total fibre requirement is added first "bags and all" to the mixer with the initial batch water. From this point normal loading procedures can be used. The mulchable bag will release the fibres which will be homogenously distributed throughout the mix after 5 minutes of mixing. 6kg of BarChip60 may reduce measured slump by between 10mm and 20mm dependent on mix design. For more detailed instructions please refer to EPC's Technical Sheet: "Batching and Mixing", available for download at <http://www.elastoplastic.com>.

Pumping

EPC's BarChip60 fibres reduce wear and tear on concrete pumps and hoses compared with steel fibre alternatives. Precaution should be taken to ensure the fibres can pass freely through the pump hopper grate.

Handling and Storage

- 3kg mulchable paper bag/432Kgs per pallet
- UV stabilized modified olefin fibre
- Shipped on durable plastic pallets
- Weather proof tarpee pallet covers
- Bulk bags available on request

EPC's UV stabilized BarChip60 fibre is supplied on durable recyclable plastic pallets with a fitted rain hood to allow storage outdoors with no environmental deterioration of product or packaging. Bags of BarChip60 stored individually must be protected from water damage to prevent bag deterioration.

For safety please refer to BarChip60 MSDS available for download at <http://www.elastoplastic.com>.

Testing

ASTM C 1550 Round Determinate Panel.

Suitable for analysis of concrete used in the following applications:

- Shotcrete
- Concrete Wall Construction
- Precast Products

ASTM C1550 round panel test offers designers, contractors and owners several important advantages over alternative forms of post-crack performance assessment. The most important of these is the low variability in sample results due to the repeat ability of the cracking pattern, but other advantages include the elimination of saw cutting during specimen production and the use of easy to prepare form work.

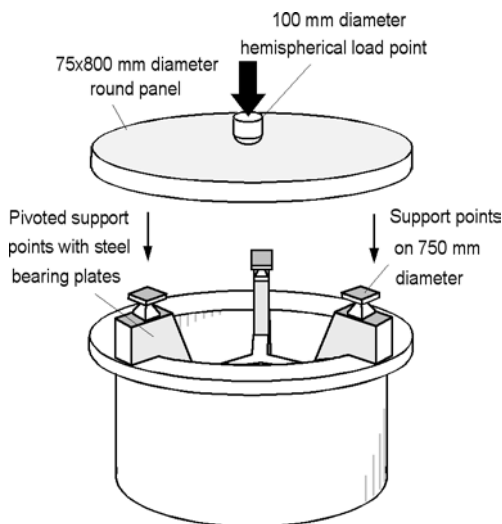

The test involves applying a point load at the centre of a round panel measuring 800mm x 75mm centred on three symmetrically arranged pivots located on a 750mm diameter circle. The loading piston is advanced at a constant rate of 4mm/min. The test proceeds to a total central deflection of 40mm after which the energy absorbed by the specimen (Joules) is measured as the area under the load-deflection curve.

Other test information is available on:

- Fire Resistance ~ anti-spalling
- Advanced Alkalinity Testing
- Long Term Durability ~ superior to steel fibre

Results

EPC BarChip60 has been independently tested against our competitors current fibres, as well as steel alternatives. The results below show the total energy absorption at a 40mm displacement

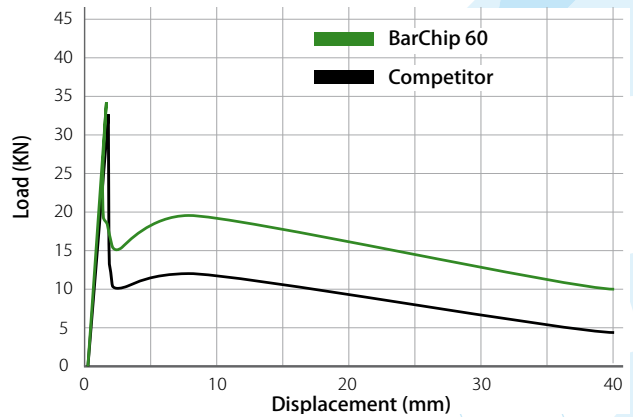

Reinforcing Material	ASTM C1550 RDP	EFNARC
EPC BarChip60 @ 5kg/m ³	530 Joules	1325 Joules
Competitor 58mm Fibre @ 5kg/m ³	362 Joules	905 Joules

(Average results over 5 panel tests)

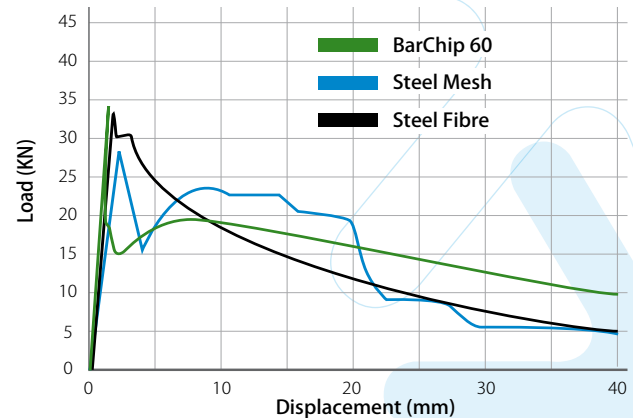

Reinforcing Material	ASTM C1550 RDP	EFNARC
EPC BarChip60 @ 5kg/m ³	530 Joules	1325 Joules
Steel Mesh (500Mpa 4mm wire 100mm centres)	475 Joules	1187 Joules
Steel Fibre @ 30kg/m ³	444 Joules	1110 Joules

(Average results over 5 panel tests)